



Battery Isolator Switch

Features & Benefits

An interchangeable labeling system allowing a full range of applications.
 Removable side plates on 4 sides for access of up to 1/0 cables plus a rear cover insulating the rear terminals against any short circuits. (SFCBS-275-201)
 ABS Anti-aging, Anti-ultraviolet.
 May be connected to either the positive or the negative electric cable.
 In the "OFF" position the key may be removed. (SFIBS1-01 only)

Typical Applications

Marine
 RV & Campers
 Industrial

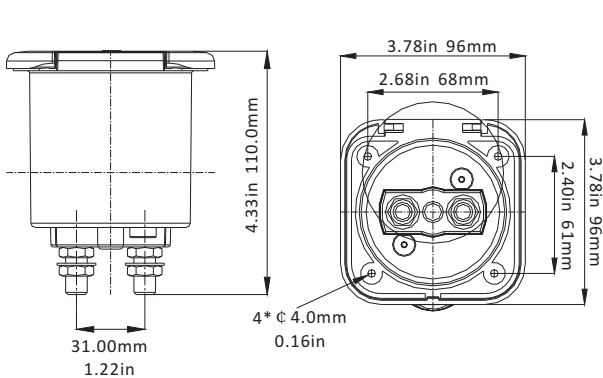

SFIBS1-01

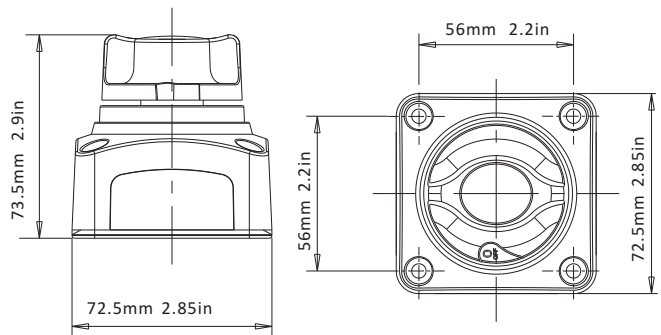

SFCBS-275-201

Model	SFIBS1-01	SFCBS-275-201
Max.Volt (V)	50	50
Amp Draw (A)	275	275
Max Amp Draw (A)	1250	1250
Switch Position	2	2
Packing Size	100×104×114 mm	78×78×80 mm
N.W/GW	0.29/0.32 kg	0.20/0.30 kg